

Demand Paging

A demand paging system is quite similar to a paging system with swapping where processes reside in secondary memory and pages are loaded only on demand, not in advance. When a context switch occurs, the operating system does not copy any of the old program's pages out to the disk or any of the new program's pages into the main memory. Instead, it just begins executing the new program after loading the first page and fetches that program's pages as they are referenced.

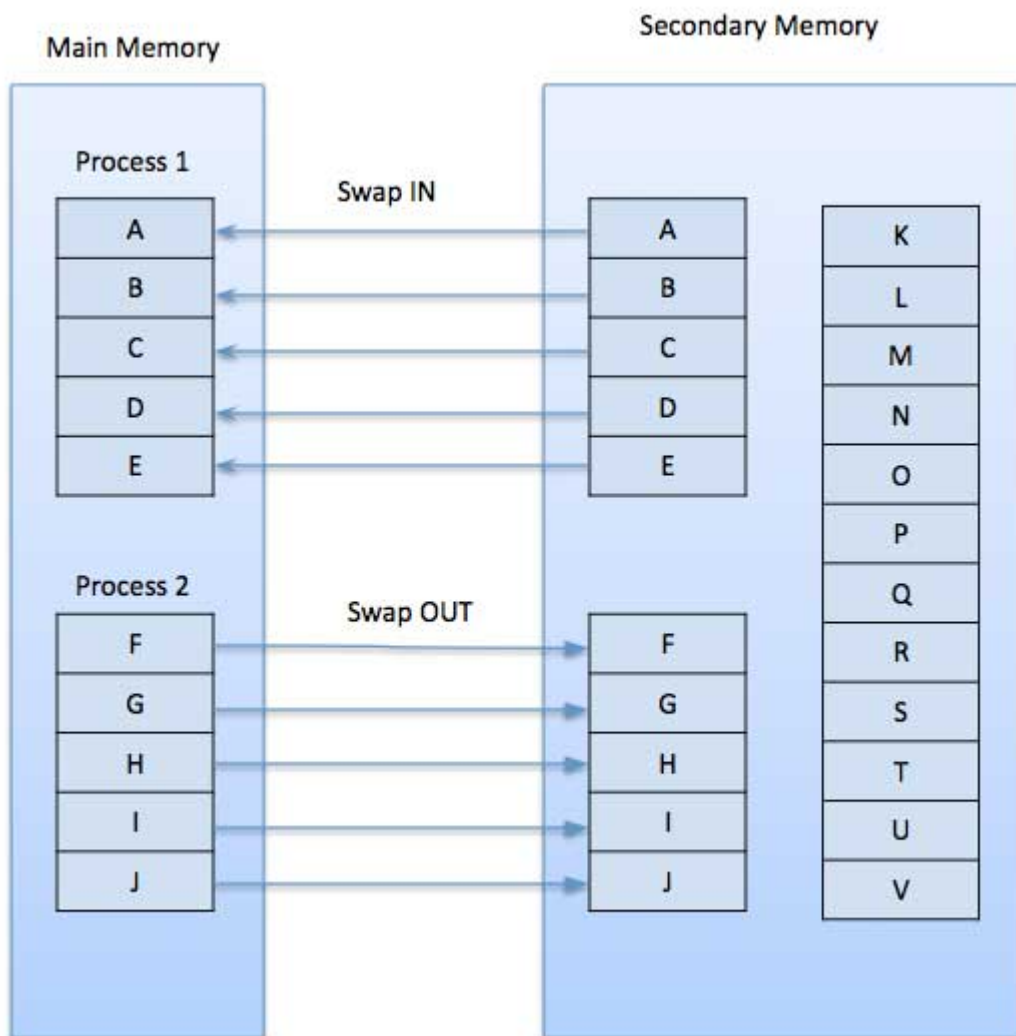

While executing a program, if the program references a page which is not available in the main memory because it was swapped out a little ago, the processor treats this invalid memory reference as a **page fault** and transfers control from the program to the operating system to demand the page back into the memory.

Advantages

Following are the advantages of Demand Paging –

- Large virtual memory.
- More efficient use of memory.
- There is no limit on degree of multiprogramming.

Disadvantages

- Number of tables and the amount of processor overhead for handling page interrupts are greater than in the case of the simple paged management techniques.